

CUSTOMER: **GUDEL** CUSTOMER ORDER REF: **[REDACTED]**
 DISTRIBUTOR: **[REDACTED]** REDEX ORDER REF: **1002075**
 DESIGNATION: **KRP1.M1.7.3.H.28/38** SERIAL NUMBER: **910872**
 CODE: **RX136585-02** MOTOR FLANGE CODE: **[REDACTED]**

EXTERNAL DIMENSIONS & INTERFACES: SN: **910872**

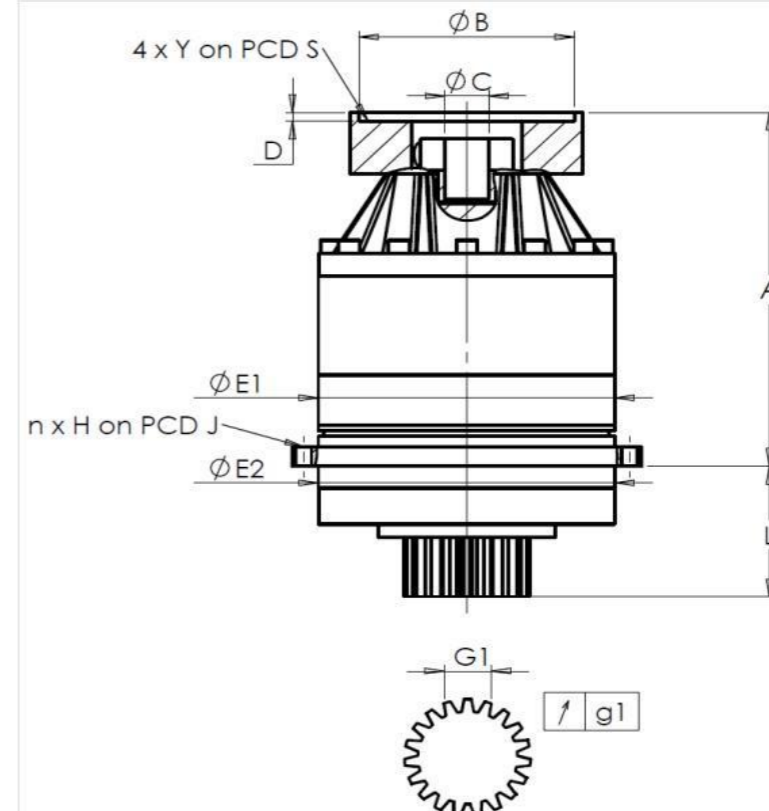

For the installation, please refer to User Manual KRP (182/008)

SPECIFIC REMARKS:

General tolerance: Js13 Cmm Automatic / manual coordinate-measuring machine µm Micrometer Cr Calliper rule Di Dial indicator Pg Plug gauge

HOUSING				OUTPUT PINION				MOTOR FLANGE			
requirement		measure		requirement		measure		requirement		measure	
		F2425				G7274				-	
E1	152h7 ⁰ _{-0,04} µm		151.985	Span dimension over 3 teeth				Ø	B		µm
E2	140h7 ⁰ _{-0,04} µm		139.985	G1	23,28 ⁰ _{-0,03} Cmm		23.258	Ø	C		µm
n x H on PCD J	12 Ø6,5 on PCD 168	Cr	12 Ø6,5 on PCD 168	g1	0,021	Di	0.02	Ø	S1		Cr
A	160	µm	160.31	No-load input torque				Ø	Y1		Pg
L	71	µm	70.72	Line 1		1,3 Nm					

Noise level			
	Line	Stiffness	@1600 rpm input (dB(A))
Torsional stiffness (Nm/arcmin)	1	81,39	61.0
Radial stiffness (N/µm)	1	404,59	

Date: **16/04/2026**

Visa: **C DE MIRANDA**

Version: **A**

Product images are for illustrative purposes only.