

CUSTOMER: **ARCO CHEER** CUSTOMER ORDER REF:
 DISTRIBUTOR: REDEX ORDER REF: **1000062**
 DESIGNATION: **KRP2.R1.21.4.H** SERIAL NUMBER: **910561**
 CODE: **RX133930-11** MOTOR FLANGE CODE:

EXTERNAL DIMENSIONS & INTERFACES: SN: **910561**

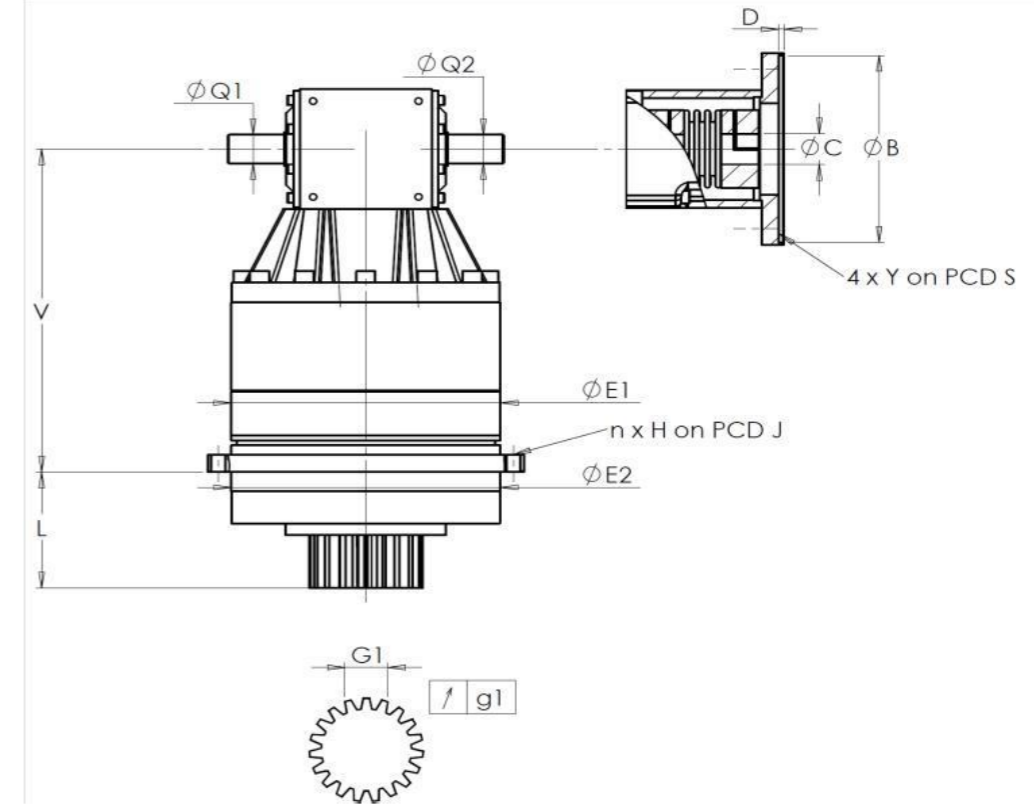

For the installation, please refer to User Manual KRP (182/008)

SPECIFIC REMARKS:

General tolerance: Js13 Cmm Automatic / manual coordinate-measuring machine μm Micrometer Cr Calliper rule Di Dial indicator Pg Plug gauge

HOUSING				OUTPUT PINION				MOTOR FLANGE			
requirement		measure		requirement		measure		requirement		measure	
		J5277				J5119				-	
E1	212h7 ⁰ _{-0,046} μm		211.99	Span dimension over 4 teeth				∅	B		μm
E2	200h7 ⁰ _{-0,046} μm		199.99	G1	44,27 ⁰ _{-0,03} Cmm		44.248	∅	C		μm
n x H on PCD J	12 ∅9 on PCD 233	Cr	12 ∅9 on PCD 233	g1	0,022	Di	0.01		D		Cr
V	289	μm	289.27	No-load input torque				∅	S1		Cr
L	94	μm	93.99	Line 1		1,3 Nm		∅	Y1		Pg
∅ Q1	25 ^{+0,009} _{-0,004} μm		24.999	Noise level						@1600 rpm input (dB(A))	67.5
∅ Q2	25 ^{+0,009} _{-0,004} μm		24.999	Torsional stiffness (Nm/arcmin)		1	243,75				
				Radial stiffness (N/μm)		1	620,35				

Date: **14/04/2026**

Visa: **C DE MIRANDA**

Version: **A**

Product images are for illustrative purposes only.