

CUSTOMER: **YONG JU PRECISION** CUSTOMER ORDER REF: ***RX113315T 07/11/24**
 DISTRIBUTOR: **REDEX ORDER REF: 219695**
 DESIGNATION: **KRP3.R1.31.4.H** SERIAL NUMBER: **910383**
 CODE: **RX135700-12** MOTOR FLANGE CODE:

EXTERNAL DIMENSIONS & INTERFACES: SN: **910383**

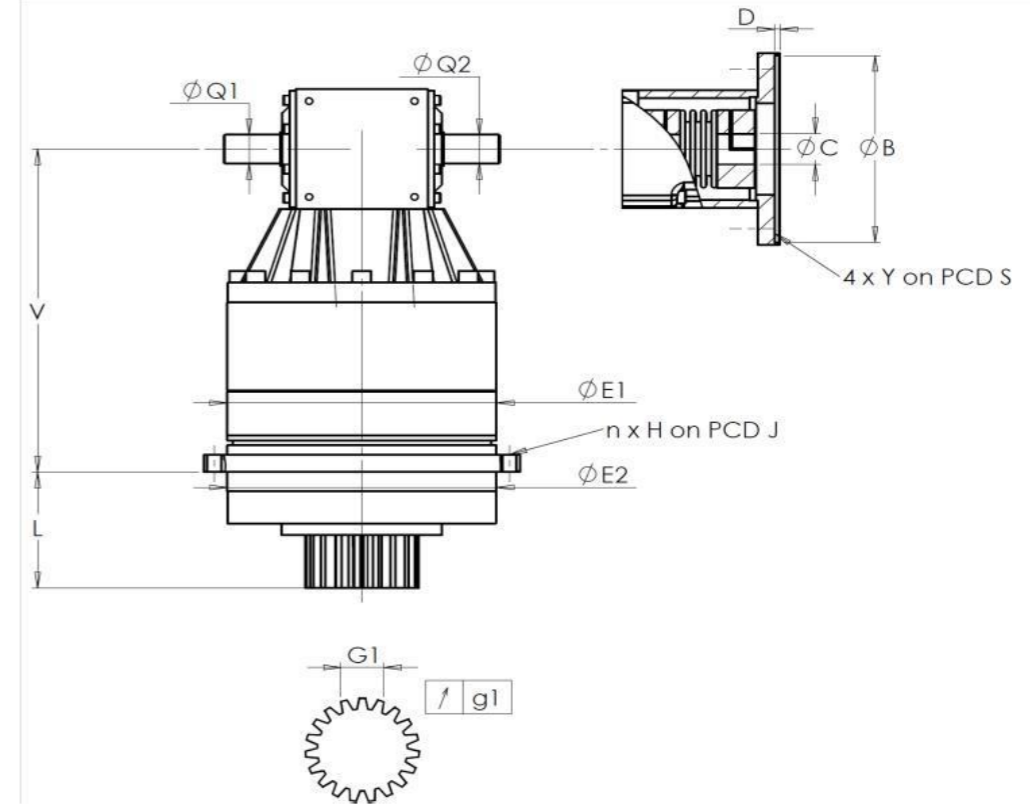

For the installation, please refer to User Manual KRP (182/008)

SPECIFIC REMARKS:

General tolerance: Js13 Cmm Automatic / manual coordinate-measuring machine μm Micrometer Cr Calliper rule Di Dial indicator Pg Plug gauge

HOUSING				OUTPUT PINION				MOTOR FLANGE			
requirement	measure			requirement	measure			requirement	measure		
			J2560				G7056				-
E1	255h7 ⁰ _{-0,052} μm		254.995	Span dimension over 3 teeth				∅	B		μm
E2	255h7 ⁰ _{-0,052} μm		254.995	G1	39,25 ⁰ _{-0,03} Cmm		39.234	∅	C		μm
n x H on PCD J	16 ∅13,5 on PCD 280	Cr	16 ∅13,5 on PCD 280	g1	0,022	Di	0.02	∅	D		Cr
V	337	μm	337.36	No-load input torque				∅	S1		Cr
L	121	μm	120.94	Line 1			2 Nm	∅	Y1		Pg
∅ Q1	30 ^{+0,009} _{-0,004} μm		29.996	Noise level							
∅ Q2	30 ^{+0,009} _{-0,004} μm		29.998		Line	Stiffness		@1600 rpm input (dB(A))			69.0
				Torsional stiffness (Nm/arcmin)	1		473,03				
				Radial stiffness (N/μm)	1		1190				

Date: **08/01/2026**

Visa: **C DE MIRANDA**

Version: **A**

Product images are for illustrative purposes only.