

CUSTOMER: REDEX SHANGHAI REPAIRING CUSTOMER ORDER REF: \*RXCN2024012609 GNCKM  
 DISTRIBUTOR: REDEX SHANGHAI REPAIRING REDEX ORDER REF: 218974  
 DESIGNATION: KRP2.M1.31.3.H.28/38 SERIAL NUMBER: 908698  
 CODE: RX133901-12 MOTOR FLANGE CODE: RX129461-01

EXTERNAL DIMENSIONS & INTERFACES: SN: 908698

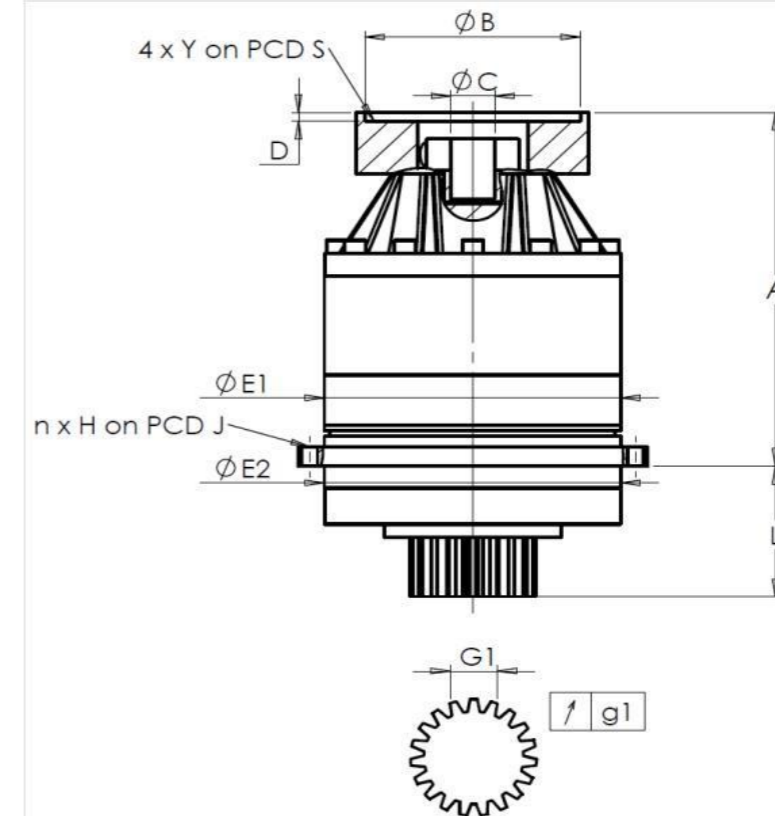

For the installation, please refer to User Manual KRP (182/008)

SPECIFIC REMARKS:

General tolerance: Js13 Cmm Automatic / manual coordinate-measuring machine µm Micrometer Cr Calliper rule Di Dial indicator Pg Plug gauge

HOUSING				OUTPUT PINION				MOTOR FLANGE			
requirement		measure		requirement		measure		requirement		measure	
		G4692				G3776					
E1	212h7 <sup>0</sup> <sub>-0,046</sub> µm	211,97	Span dimension over 4 teeth				Ø B	131 µm	131		
E2	200h7 <sup>0</sup> <sub>-0,046</sub> µm	199,97	G1	44,27 <sup>0</sup> <sub>-0,03</sub> Cmm	44,245	Ø C	32 <sup>+0,05</sup> <sub>+0,025</sub> µm	32,025			
n x H on PCD J	12 Ø9 on PCD 233	Cr 12 Ø9 on PCD 233	g1	0,022	Di 0,01	Ø D	5	Cr 5,51			
A	273 µm	273,62	No-load input torque				Ø S1	165	Cr 165		
L	94 µm	93,88	Line 1		0,7 Nm		Ø Y1	M10	Pg M10		

		Line	Stiffness	Noise level	
				@1600 rpm input (dB(A))	66,5
Torsional stiffness (Nm/arcmin)	1	243,75			
Radial stiffness (N/µm)	1	566			

Date: 15/05/2024

Visa: C DE MIRANDA

Version: A

Product images are for illustrative purposes only.