

CUSTOMER: SENN KONSTRUKTION CUSTOMER ORDER REF: \*7227/SH ENDRESS+HAUSER  
 DISTRIBUTOR: REDEX ORDER REF: 218151  
 DESIGNATION: KRP5+MX.105.3.H.28/38 SERIAL NUMBER: 908365  
 CODE: RX135937-00 MOTOR FLANGE CODE: RX129461-05

EXTERNAL DIMENSIONS & INTERFACES: SN: 908365

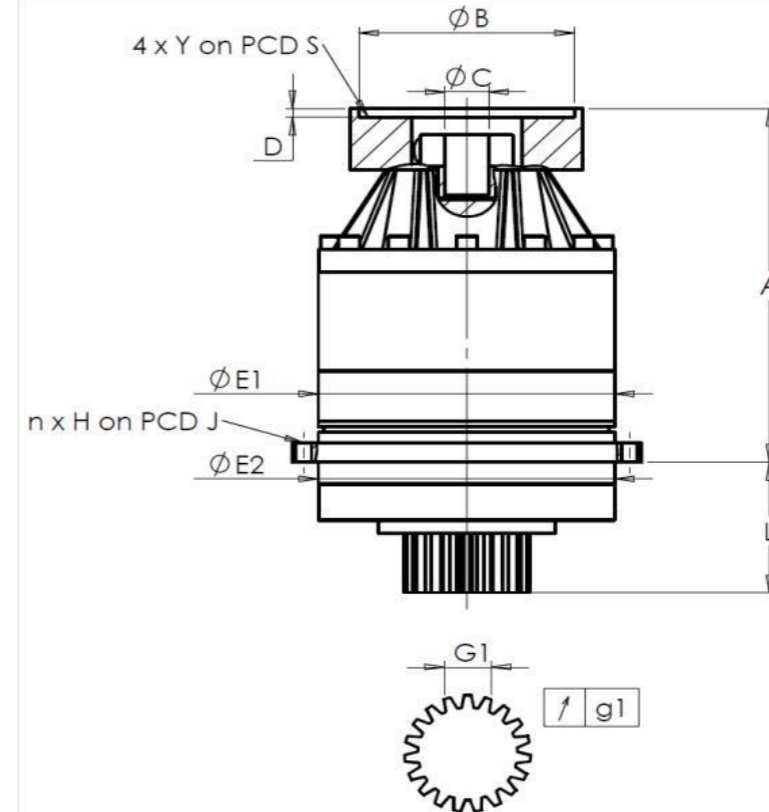

General tolerance: Js13 Cmm Automatic / manual coordinate-measuring machine µm Micrometer Cr Calliper rule Di Dial indicator Pg Plug gauge

For the installation, please refer to User Manual KRP (182/008)

SPECIFIC REMARKS:

HOUSING				OUTPUT PINION				MOTOR FLANGE				
requirement		measure		requirement		measure		requirement		measure		
		G127				F6907						
E1	355j6 <sup>+0,018</sup> / <sub>-0,018</sub>	µm	355,01	Span dimension over 3 teeth				Ø	B	131	µm	131
E2	355j6 <sup>+0,018</sup> / <sub>-0,018</sub>	µm	355,005	G1	62,97 <sup>0</sup> / <sub>-0,05</sub>	Cmm	62,97	Ø	C	32F7 <sup>+0,050</sup> / <sub>+0,025</sub>	µm	32,04
n x H on PCD J	12 Ø17,5 on PCD 385	Cr	12 Ø17,5 on PCD 385	g1	0,03	Di	0,01	Ø	D	5	Cr	5,5
A	523	µm	523,98	No-load input torque				Ø	S1	165	Cr	165
L	178	µm	177,66	Line 1		0,6 Nm		Ø	Y1	M10	Pg	M10

Noise level			
	Line	Stiffness	@1600 rpm input (dB(A))
Torsional stiffness (Nm/arcmin)	1	1076,47	64,0
Radial stiffness (N/µm)	1	1420	

Date: 19/02/2024

Visa: C DE MIRANDA

Version: A

Product images are for illustrative purposes only.