

CUSTOMER: **YONG JU PRECISION TECHNOLOGY** CUSTOMER ORDER REF: **RX112305T YONG JU**  
 DISTRIBUTOR: **REDEX** REDEX ORDER REF: **217819**  
 DESIGNATION: **KRP2.R1.31.4.H** SERIAL NUMBER: **908216**  
 CODE: **RX133930-12** MOTOR FLANGE CODE:

EXTERNAL DIMENSIONS & INTERFACES: SN: **908216**

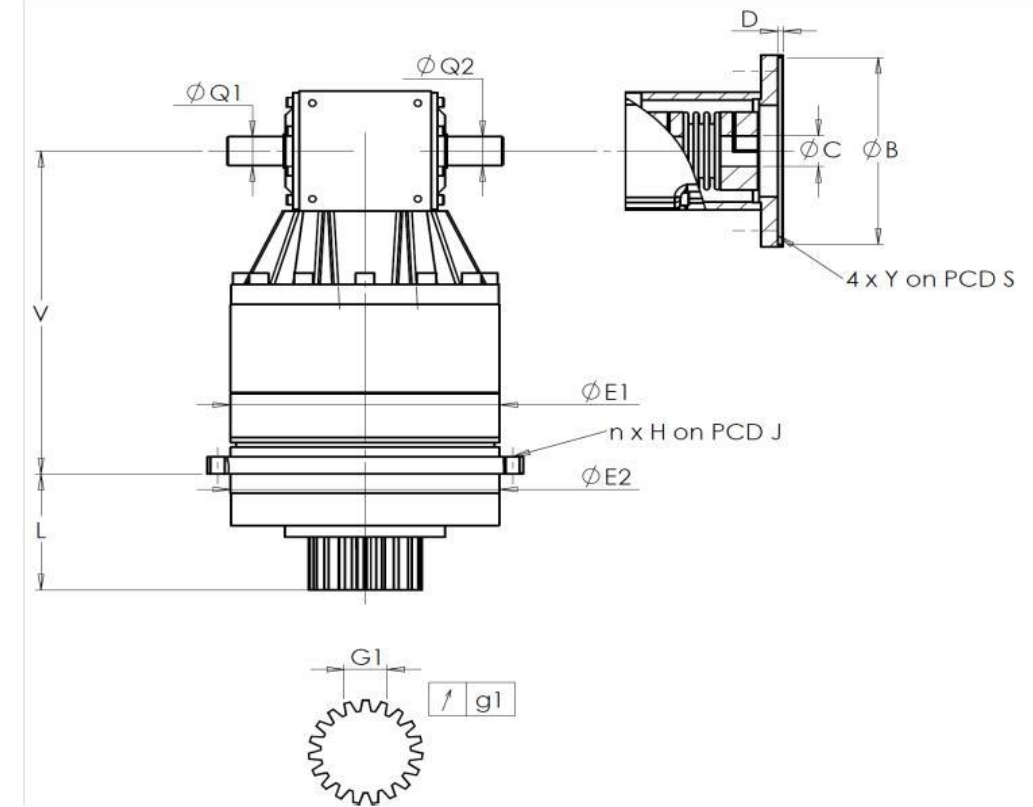

For the installation, please refer to User Manual KRP (182/008)

SPECIFIC REMARKS:

General tolerance: Js13 *Cmm* Automatic / manual coordinate-measuring machine  $\mu m$  Micrometer *Cr* Calliper rule *Di* Dial indicator *Pg* Plug gauge

HOUSING				OUTPUT PINION				MOTOR FLANGE			
requirement		measure		requirement		measure		requirement		measure	
		G1485				F4803				-	
E1	212h7 <sup>0</sup> <sub>-0,046</sub> $\mu m$		211,98	Span dimension over 4 teeth				Ø	B		$\mu m$
E2	200h7 <sup>0</sup> <sub>-0,046</sub> $\mu m$		199,99	G1	44,27 <sup>0</sup> <sub>-0,03</sub> <i>Cmm</i>		44,25	Ø	C		$\mu m$
n x H on PCD J	12 Ø9 on PCD 233	<i>Cr</i>	12 Ø9 on PCD 233	g1	0,022	<i>Di</i>	0,01	Ø	D		<i>Cr</i>
V	289	$\mu m$	289,35	No-load input torque				Ø	S1		<i>Cr</i>
L	94	$\mu m$	93,86	Line 1		1,1 Nm		Ø	Y1		<i>Pg</i>
Ø	Q1	25 <sup>+0,009</sup> <sub>-0,004</sub> $\mu m$	25,008					Noise level			
Ø	Q2	25 <sup>+0,009</sup> <sub>-0,004</sub> $\mu m$	25,008			Line	Stiffness	@1600 rpm input (dB(A))		69,0	
				Torsional stiffness (Nm/arcmin)		1	243,75				
				Radial stiffness (N/ $\mu m$ )		1	649				

Date: **15/12/2023**

Visa: **C DE MIRANDA**

Version: **A**

Product images are for illustrative purposes only.