

CUSTOMER: **REDEX SHANGHAI REPAIRING** CUSTOMER ORDER REF: ***RXCN20230718044 GNCKM**
 DISTRIBUTOR: **REDEX ORDER REF: 218096**
 DESIGNATION: **KRP2.M1.31.3.H.28/38** SERIAL NUMBER: **908113**
 CODE: **RX133901-12** MOTOR FLANGE CODE: **RX129461-01**

EXTERNAL DIMENSIONS & INTERFACES: SN: **908113**

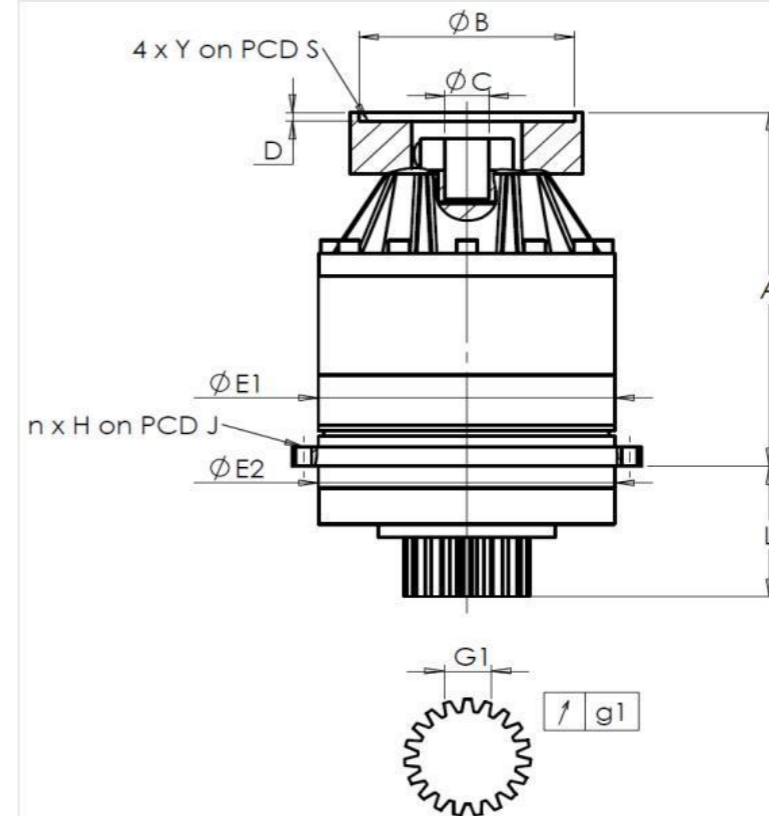

For the installation, please refer to User Manual KRP (182/008)

SPECIFIC REMARKS:

General tolerance: Js13 Cmm Automatic / manual coordinate-measuring machine µm Micrometer Cr Calliper rule Di Dial indicator Pg Plug gauge

HOUSING				OUTPUT PINION				MOTOR FLANGE			
requirement		measure		requirement		measure		requirement		measure	
		F2463				F4838					
E1	212h7 ⁰ _{-0,046} µm	211,98	Span dimension over 4 teeth				Ø B	131 µm	131		
E2	200h7 ⁰ _{-0,046} µm	199,98	G1	44,27 ⁰ _{-0,03} Cmm	44,253	Ø C	32 ^{+0,05} _{+0,025} µm	32,03			
n x H on PCD J	12 Ø9 on PCD 233 Cr	12 Ø9 on PCD 233 Cr	g1	0,022 Di	0,01	Ø D	5 Cr	5,46			
A	273 µm	273,79	No-load input torque				Ø S1	165 Cr	165		
L	94 µm	93,92	Line 1		0,7 Nm	Ø Y1	M10 Pg	M10			

Noise level		
	Line	Stiffness
Torsional stiffness (Nm/arcmin)	1	-180
Radial stiffness (N/µm)	1	616

@1600 rpm input (dB(A)) 66,0

Date: **21/11/2023**

Visa: **C DE MIRANDA**

Version: **A**

Product images are for illustrative purposes only.