

CUSTOMER: **TARUS** CUSTOMER ORDER REF: ***33486-00 TARUS**
 DISTRIBUTOR: **REDEX ORDER REF: 217994**
 DESIGNATION: **KRP0+M.10.3.143H.B5.22/32** SERIAL NUMBER: **908002**
 CODE: **RX135918-03** MOTOR FLANGE CODE: **RX128707-05**

EXTERNAL DIMENSIONS & INTERFACES: SN: **908002**

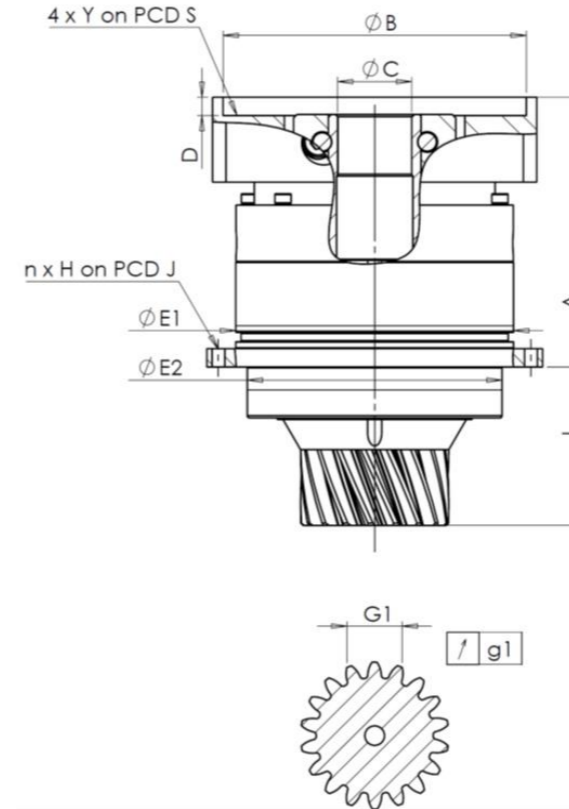

General tolerance: Js13 *Cmm* Automatic / manual coordinate-measuring machine μm Micrometer *Cr* Calliper rule *Di* Dial indicator *Pg* Plug gauge

For the installation, please refer to User Manual KRP (182/008)

SPECIFIC REMARKS:

HOUSING				OUTPUT PINION				MOTOR FLANGE					
requirement		measure		requirement		measure		requirement		measure			
		H1965				G1461							
Ø	E1	120h7 ⁰ _{-0,035}	μm	119,995	Span dimension over 3 teeth				Ø	B	131	μm	131
Ø	E2	110h7 ⁰ _{-0,035}	μm	109,98	G1	23,466 ^{-0,071} _{-0,082}	<i>Cmm</i>	23,388	Ø	C	32 ^{+0,05} _{+0,025}	μm	32,025
n x H on PCD J		8Ø5,5 on PCD 135	<i>Cr</i>	8Ø5,5 on PCD 135	g1	0,021	<i>Di</i>	0,015	Ø	D	8	<i>Cr</i>	8,52
		A	μm	117,78	No-load input torque				Ø	S1	165	<i>Cr</i>	165
		L	μm	69,36	Line 1		0,2 Nm		Ø	Y1	M10	<i>Pg</i>	M10

Noise level			
		Line	Stiffness
		1600 rpm input (dB(A))	
		67,5	
Torsional stiffness (Nm/arcmin)	1	40	
Radial stiffness (N/ μm)	1	160	

Date: **05/10/2023**

Visa: **C DE MIRANDA**

Version: **A**

Product images are for illustrative purposes only.