

CUSTOMER: REDEX SHANGHAI REPAIRING CUSTOMER ORDER REF: *RXCN2023062942 CHR
 DISTRIBUTOR: REDEX SHANGHAI REPAIRING REDEX ORDER REF: 217972
 DESIGNATION: KRP5+M.91.3.S.22/32 SERIAL NUMBER: 907958
 CODE: RX135359-33 MOTOR FLANGE CODE: RX135358-00

EXTERNAL DIMENSIONS & INTERFACES: SN: 907958

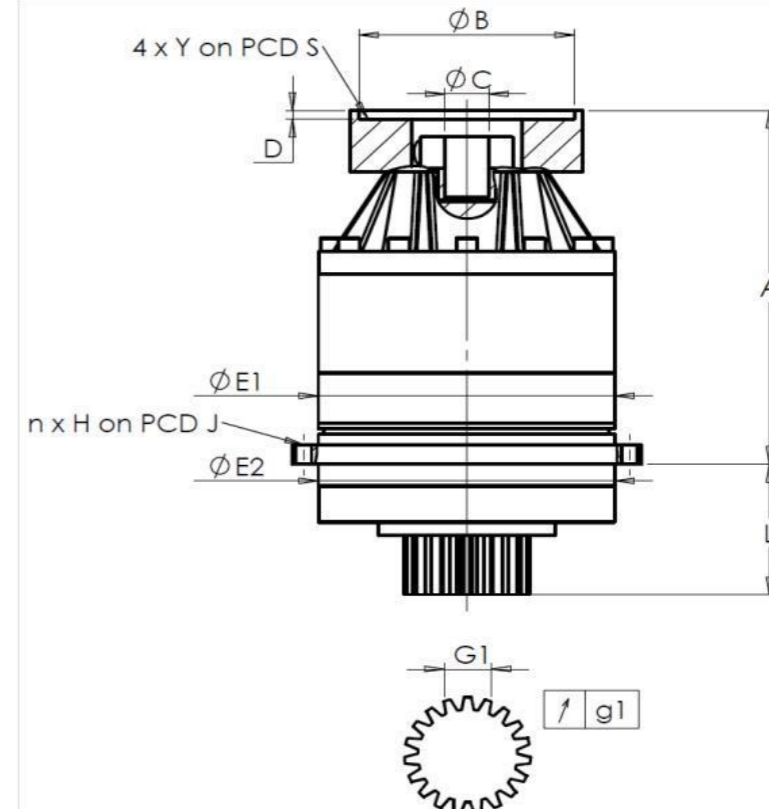

For the installation, please refer to User Manual KRP (182/008)

SPECIFIC REMARKS:

General tolerance: Js13 Cmm Automatic / manual coordinate-measuring machine µm Micrometer Cr Calliper rule Di Dial indicator Pg Plug gauge

HOUSING				OUTPUT PINION				MOTOR FLANGE				
requirement		measure		requirement		measure		requirement		measure		
		G2072				F3373						
E1	355j6 ^{+0,018} _{-0,018}	µm	355,01	Span dimension over 3 teeth				Ø	B	111	µm	111
E2	355j6 ^{+0,018} _{-0,018}	µm	355,01	G1	62,54 ⁰ _{-0,05}	Cmm	62,52	Ø	C	32F7 ^{+0,05} _{+0,025}	µm	32,025
n x H on PCD J	12 Ø17,5 on PCD 385	Cr	12 Ø17,5 on PCD 385	g1	0,03	Di	0,02	Ø	S1	130	Cr	130
A	421	µm	421,98	No-load input torque				Ø	Y1	4xM8	Pg	4xM8
L	178	µm	177,86	Line 1		1,2 Nm						

Noise level			
	Line	Stiffness	@1000 rpm input (dB(A))
Torsional stiffness (Nm/arcmin)	1	1076,47	55,5
Radial stiffness (N/µm)	1	1271	

Date: 26/09/2023

Visa: C DE MIRANDA

Version: A

Product images are for illustrative purposes only.