

CUSTOMER: **KRC** CUSTOMER ORDER REF: **\*33270-00 KRC**  
 DISTRIBUTOR: **ANDANTEX INCORPORATED** REDEX ORDER REF: **217734**  
 DESIGNATION: **DRP4+M.31.3.H.35/48** SERIAL NUMBER: **907941**  
 CODE: **RX129702-12** MOTOR FLANGE CODE: **RX128583-10**

For the installation, please refer to User Manual DRP (182/009)

SPECIFIC REMARKS:  
\*Accepted according to Redex derogation RX12771.

Product images are for illustrative purposes only.

EXTERNAL DIMENSIONS & INTERFACES: SN: **907941**

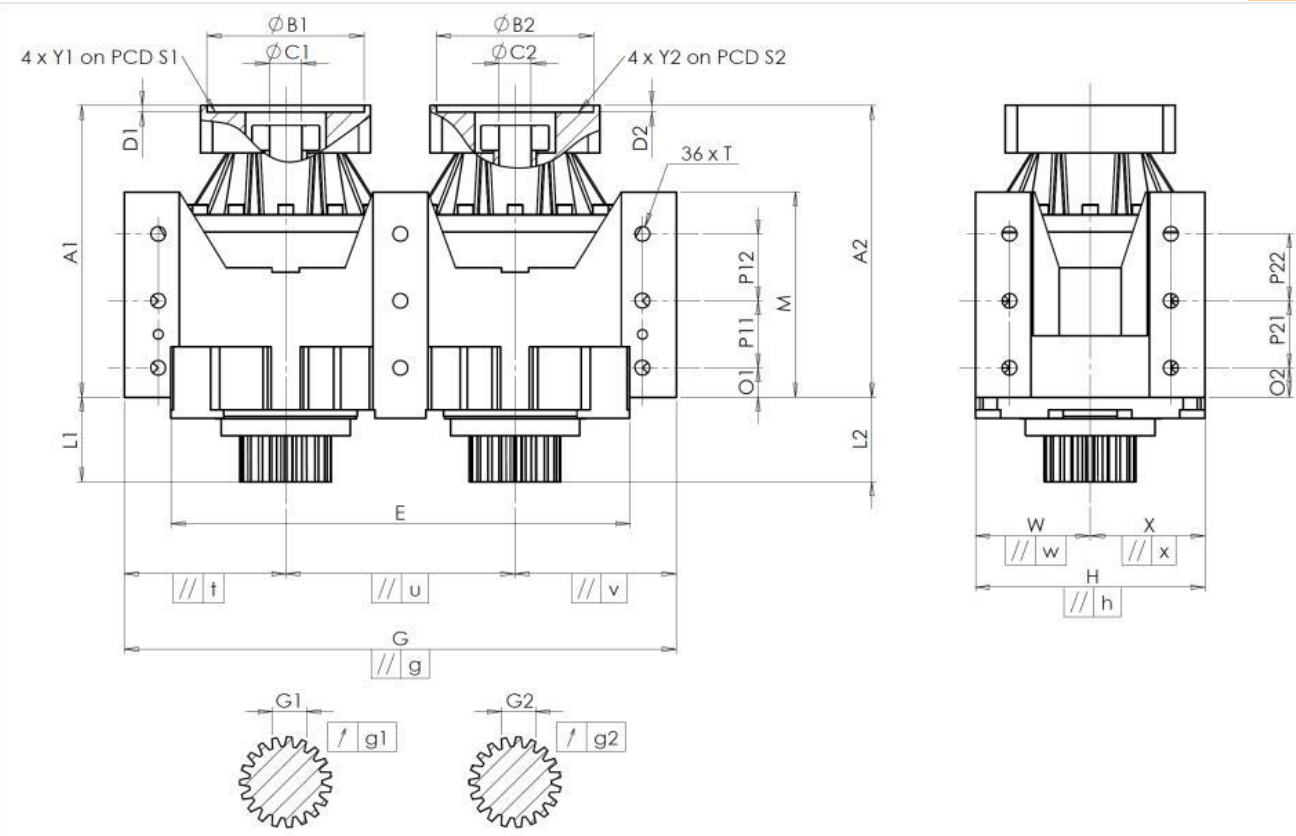

General tolerance: Js13 Cmm Automatic / manual coordinate-measuring machine µm Micrometer Cr Calliper rule Di Dial indicator Pg Plug gauge

HOUSING				HOUSING				MOTOR FLANGE			
requirement	measure			requirement	measure			requirement	measure		
	E6309			O1	43	Cr	43	Ø B1	181	µm	181
E	640 <sup>0</sup> <sub>-0,1</sub>	Cmm	639,94	P11	100	Cr	100	Ø C1	38 <sup>+0,05</sup> <sub>+0,025</sub>	µm	38,04
G	800 <sup>+0,2</sup> <sub>-0,2</sub>	Cmm	799,65 *	M	288 <sup>+0,1</sup> <sub>-0,1</sub>	Cmm	288,02	D1	8	Cr	8,51
// g	0,05	Cmm	0,02	O2	43	Cr	43	Ø S1	215	Cr	215
// t	0,05	Cmm	0,005	P21	100	Cr	100	Ø Y1	M12	Pg	M12
// u	0,035	Cmm	0,005	P22	100	Cr	100	Ø B2	181	µm	181
// v	0,05	Cmm	0,01	Ø T	M24	Pg	M24	Ø C2	38 <sup>+0,05</sup> <sub>+0,025</sub>	µm	38,04
W	160	Cmm	160,005	OUTPUT PINION				D2	8	Cr	8,49
// w	0,04	Cmm	0,005					Pinion 1		F5566	Ø S2
X	160	Cmm	160,01	Span dimension over 3 teeth				Ø Y2	M12	Pg	M12
// x	0,04	Cmm	0,005	G1	46,9 <sup>0</sup> <sub>-0,03</sub>	Cmm	46,885	Line			Stiffness
H	320 <sup>+0,04</sup> <sub>-0,04</sub>	Cmm	320,015	g1	0,022	Di	0,02				
// h	0,02	Cmm	0,015	Pinion 2				F5563	2	745,99	
A1	404,5	Cmm	405,52	Span dimension over 3 teeth				Radial stiffness (N/µm)			
L1	120	Cmm	120,2	G2	46,9 <sup>0</sup> <sub>-0,03</sub>	Cmm	46,88	1	1028		
A2	404,5	Cmm	405,35	g2	0,022	Di	0,02	2	1294		
L2	120	Cmm	120	No-load input torque				Noise level			
				Line 1				@ 1300 rpm input (dB(A))			
				Line 2				70,0			

Date: **23/10/2023**

Visa: **C DE MIRANDA**

Version: **A**