

CUSTOMER: SOLUTION TRADING CUSTOMER ORDER REF: *PO-00130 31/05/23
 DISTRIBUTOR: REDEX ORDER REF: 217901
 DESIGNATION: KRP2+M.31.3.S.28/38 SERIAL NUMBER: 907846
 CODE: RX129987-12 MOTOR FLANGE CODE: RX128581-06

EXTERNAL DIMENSIONS & INTERFACES: SN: 907846

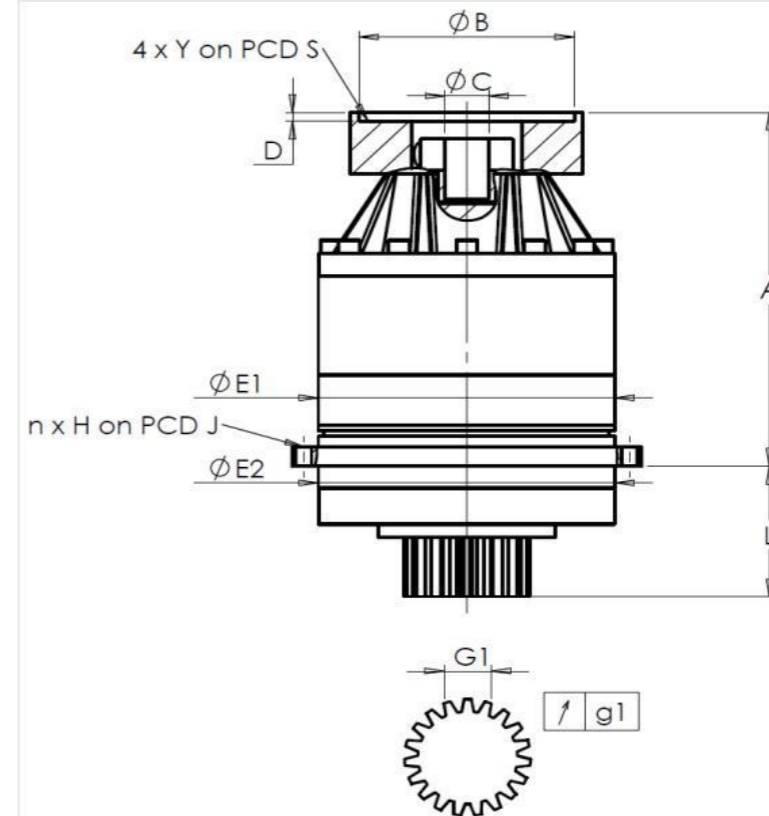

For the installation, please refer to User Manual KRP (182/008)

SPECIFIC REMARKS:

General tolerance: Js13 Cmm Automatic / manual coordinate-measuring machine µm Micrometer Cr Calliper rule Di Dial indicator Pg Plug gauge

HOUSING				OUTPUT PINION				MOTOR FLANGE			
requirement		measure		requirement		measure		requirement		measure	
		F3565				F3761					
E1	212h7 ⁰ _{-0,046} µm	211,98	Span dimension over 4 teeth				Ø B	181 µm	181		
E2	200h7 ⁰ _{-0,046} µm	199,99	G1	44,27 ⁰ _{-0,03} Cmm	44,255	Ø C	38 ^{+0,05} _{+0,025} µm	38,03			
n x H on PCD J	12 Ø9 on PCD 233 Cr	12 Ø9 on PCD 233 Cr	g1	0,022 Di	0,02	Ø D	8 Cr	8,43	Ø S1	215 Cr	215
A	298 µm	298,77	No-load input torque				Ø Y1	M12 Pg	M12		
L	94 µm	93,93	Line 1		0,8 Nm						

Noise level					
		Line	Stiffness	@1600 rpm input (dB(A))	63,0
Torsional stiffness (Nm/arcmin)	1	243,75			
Radial stiffness (N/µm)	1	604			

Date: 01/08/2023

Visa: C DE MIRANDA

Version: A

Product images are for illustrative purposes only.