

CUSTOMER: REDEX SHANGHAI REPAIRING CUSTOMER ORDER REF: \*RXCN2023041425 PMSH  
 DISTRIBUTOR: REDEX SHANGHAI REPAIRING REDEX ORDER REF: 217784  
 DESIGNATION: KRP2.M1.31.3.H.28/38 SERIAL NUMBER: 907767  
 CODE: RX133901-12 MOTOR FLANGE CODE: RX128581-01

EXTERNAL DIMENSIONS & INTERFACES: SN: 907767

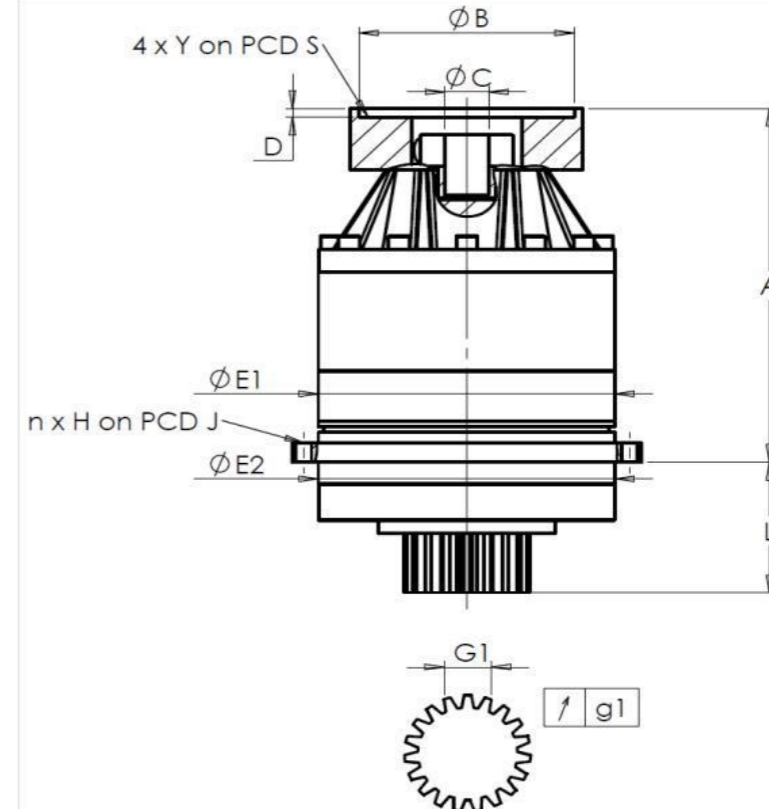

General tolerance: Js13 Cmm Automatic / manual coordinate-measuring machine µm Micrometer Cr Calliper rule Di Dial indicator Pg Plug gauge

For the installation, please refer to User Manual KRP (182/008)

SPECIFIC REMARKS:

HOUSING				OUTPUT PINION				MOTOR FLANGE			
requirement		measure		requirement		measure		requirement		measure	
		G1721				F2829					
E1	212h7 <sup>0</sup> <sub>-0,046</sub> µm		211,99	Span dimension over 4 teeth				Ø B	181 µm		181
E2	200h7 <sup>0</sup> <sub>-0,046</sub> µm		199,99	G1	44,27 <sup>0</sup> <sub>-0,03</sub> Cmm		44,25	Ø C	38 <sup>+0,05</sup> <sub>+0,025</sub> µm		38,025
n x H on PCD J	12 Ø9 on PCD 233	Cr	12 Ø9 on PCD 233	g1	0,022	Di	0,01	Ø S1	215	Cr	215
A	288 µm		288,91	No-load input torque				Ø Y1	M12	Pg	M12
L	94 µm		93,91	Line 1		0,7 Nm					

		Line	Stiffness	Noise level	
				@1600 rpm input (dB(A))	66,0
Torsional stiffness (Nm/arcmin)	1		243,75		
Radial stiffness (N/µm)	1		643		

Date: 21/07/2023

Visa: C DE MIRANDA

Version: A

Product images are for illustrative purposes only.