

CUSTOMER: **REDEX SHANGHAI REPAIRING** CUSTOMER ORDER REF: ***RXCN2023041425 PMSH**
 DISTRIBUTOR: **REDEX SHANGHAI REPAIRING** REDEX ORDER REF: **217784**
 DESIGNATION: **KRP2.M1.31.3.H.28/38** SERIAL NUMBER: **907766**
 CODE: **RX133901-12** MOTOR FLANGE CODE: **RX128581-01**

EXTERNAL DIMENSIONS & INTERFACES: SN: **907766**

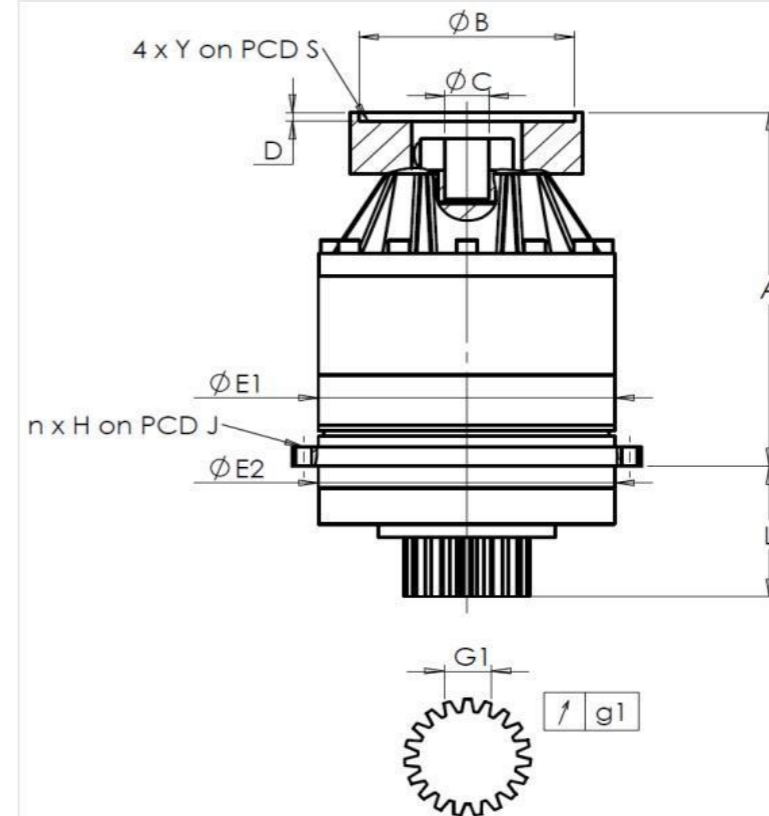

General tolerance: Js13 *Cmm* Automatic / manual coordinate-measuring machine μm Micrometer *Cr* Calliper rule *Di* Dial indicator *Pg* Plug gauge

For the installation, please refer to User Manual KRP (182/008)

SPECIFIC REMARKS:

HOUSING				OUTPUT PINION				MOTOR FLANGE			
requirement		measure		requirement		measure		requirement		measure	
		F3577				F2820					
E1	212h7 ⁰ _{-0,046} μm	211,99	Span dimension over 4 teeth				Ø B	181 μm	181		
E2	200h7 ⁰ _{-0,046} μm	199,99	G1	44,27 ⁰ _{-0,03} <i>Cmm</i>	44,25	Ø C	38 ^{+0,05} _{+0,025} μm	38,03			
n x H on PCD J	12 Ø9 on PCD 233 <i>Cr</i>	12 Ø9 on PCD 233 <i>Cr</i>	g1	0,022 <i>Di</i>	0,01	Ø D	8 <i>Cr</i>	8,53	Ø S1	215 <i>Cr</i>	215
A	288 μm	288,89	No-load input torque				Ø Y1	M12 <i>Pg</i>	M12		
L	94 μm	93,87	Line 1		0,6 Nm						

			Noise level	
			@1600 rpm input (dB(A))	62,0
Torsional stiffness (Nm/arcmin)	1	243,75		
Radial stiffness (N/ μm)	1	571		

Date: **21/07/2023**

Visa: **C DE MIRANDA**

Version: **A**

Product images are for illustrative purposes only.