

CUSTOMER: **ACCELERATED MACHINE** CUSTOMER ORDER REF: ***33133-00 ACCELERATED MACH**
 DISTRIBUTOR: **ANDANTEX INCORPORATED** REDEX ORDER REF: **217575**
 DESIGNATION: **KRP4+M.21.3.H.35/48** SERIAL NUMBER: **907593**
 CODE: **RX128414-11** MOTOR FLANGE CODE: **RX129618-08**

EXTERNAL DIMENSIONS & INTERFACES: SN: **907593**

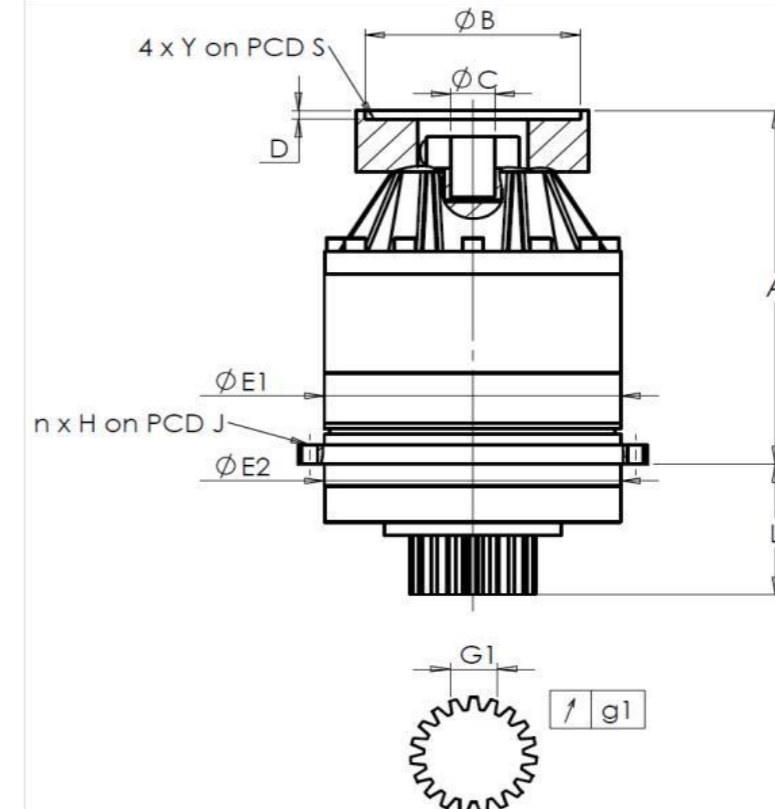

For the installation, please refer to User Manual KRP (182/008)

SPECIFIC REMARKS:

General tolerance: Js13 Cmm Automatic / manual coordinate-measuring machine µm Micrometer Cr Calliper rule Di Dial indicator Pg Plug gauge

HOUSING				OUTPUT PINION				MOTOR FLANGE			
requirement		measure		requirement		measure		requirement		measure	
		F5600				H774					
E1	285h7 ⁰ _{-0,052} µm	284,97	Span dimension over 3 teeth				Ø B	251 µm	251		
E2	285h7 ⁰ _{-0,052} µm	284,97	G1	46,9 ⁰ _{-0,03} Cmm	46,891	Ø C	48 ^{+0,05} _{+0,025} µm	48,03			
n x H on PCD J	16 Ø14 on PCD 310	16 Ø14 on PCD 310	g1	0,022	0,02	Ø D	8	8,5			
A	374,5 µm	375,13	No-load input torque				Ø S1	300	300		
L	141 µm	140,95	Line 1				Ø Y1	M18	M18		
								Noise level			
								@1300 rpm input (dB(A))		61,0	

	Line	Stiffness
Torsional stiffness (Nm/arcmin)	1	574,81
Radial stiffness (N/µm)	1	1236

Date: **22/05/2023**

Visa: **C DE MIRANDA**

Version: **A**

Product images are for illustrative purposes only.