

CUSTOMER: REDEX SHANGHAI **CUSTOMER ORDER REF:** *RXCN2022091646 IO

DISTRIBUTOR: REDEX SHANGHAI REPAIRING **REDEX ORDER REF:** 217218

DESIGNATION: KRPX3+M.31.3.H.28/38 **SERIAL NUMBER:** 907164

CODE: RX131507-12 **MOTOR FLANGE CODE:** RX128581-01

For the installation, please refer to User Manual KRPX (182/010)

SPECIFIC REMARKS:

Product images are for illustrative purposes only.



1, Rue Paul De Fontenay
F- 45210 FERRIERES
www.redex-group.com

Tel: +33 2 38 94 42 00
Fax: +33 2 38 94 42 99
Email: info@redex-group.com

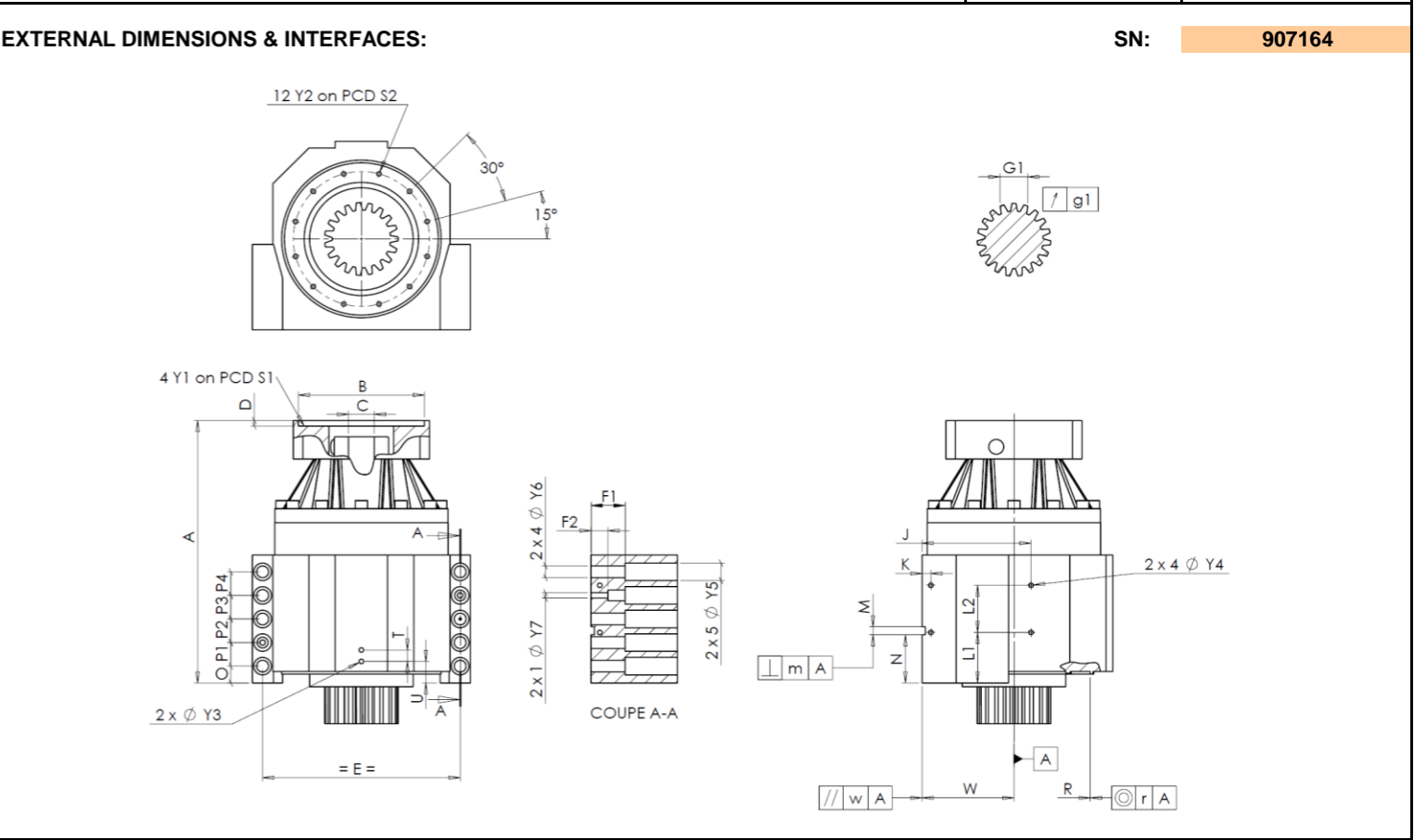

General tolerance: Js13 Cmm Automatic / manual coordinate-measuring machine µm Micrometer Cr Calliper rule Di Dial indicator Pg Plug gauge

HOUSING				HOUSING				MOTOR FLANGE						
requirement		measure		requirement		measure		requirement		measure				
			F87		L1	75	Cr	75						
	Y2	M8x15	Pg	M8x15	L2	70	Cr	70	Ø	B	181	µm	180,94	
Ø	S2	200 ^{+0,1} _{-0,1}	Cr	199,92	J	160	Cr	160	Ø	C	38 ^{+0,05} _{+0,025}	µm	38,03	
	A	389,5	µm	389,59	K	13	Cr	13		D	8	Cr	8,49	
	E	290	Cr	290	2 x 4Ø	Y4	M8x15	Pg	M8x15	Ø	S1	215	Cr	215
	O	25	Cr	25		F1	50	Cr	50	Ø	Y1	M12	Pg	M12
	P1	35	Cr	35		F2	25	Cr	25	No-load input torque				
	P2	35	Cr	35	2 x 1Ø	Y7	12	µm	12					Line 1
	P3	35	Cr	35	2 x 4Ø	Y6	17,5	µm	17,5	Line Stiffness				
	P4	35	Cr	35	2 x 5Ø	Y5	26	µm	26					Torsional stiffness (Nm/arcmin)
	T	17	Cr	17		M H6	12 ^{+0,011} ₀	Cmm	12,004	Radial stiffness (N/µm)		1	1168	
	U	32	Cr	32	⊥	m	0,05	Cmm	0,012					
2 x 1Ø	Y3	M8x15	Pg	M8x15		N	71,5 ^{+0,1} _{-0,1}	Cmm	71,468					
	R	226 ^{+0,2} _{+0,1}	Cmm	226,141	A	W	135 ^{+0,035} _{-0,035}	Cmm	135,019					
◎	r	0,1	Cmm	0,02	//	w	0,03	/A	Cmm	0,001				

OUTPUT PINION				Noise level	
			F834	@1600 rpm input (dB(A))	64,0
Span dimension over 3 teeth					
	G1	39,25 ⁰ _{-0,03}	Cmm	39,235	
↗	g1	0,022	Di	0,02	

Date: 13/12/2022

Version: A

Visa: P VASLIER



1, Rue Paul De Fontenay
F- 45210 FERRIERES
www.redex-group.com

Tel: +33 2 38 94 42 00
Fax: +33 2 38 94 42 99
Email: info@redex-group.com