

CUSTOMER: **REDEX SHANGHAI** CUSTOMER ORDER REF: ***RXCN2022063029**
 DISTRIBUTOR: **REDEX SHANGHAI REPAIRING** REDEX ORDER REF: **217064**
 DESIGNATION: **KRP3+M.21.3.H.28/38** SERIAL NUMBER: **907046**
 CODE: **RX129016-11** MOTOR FLANGE CODE: **RX128581-01**

EXTERNAL DIMENSIONS & INTERFACES: SN: **907046**

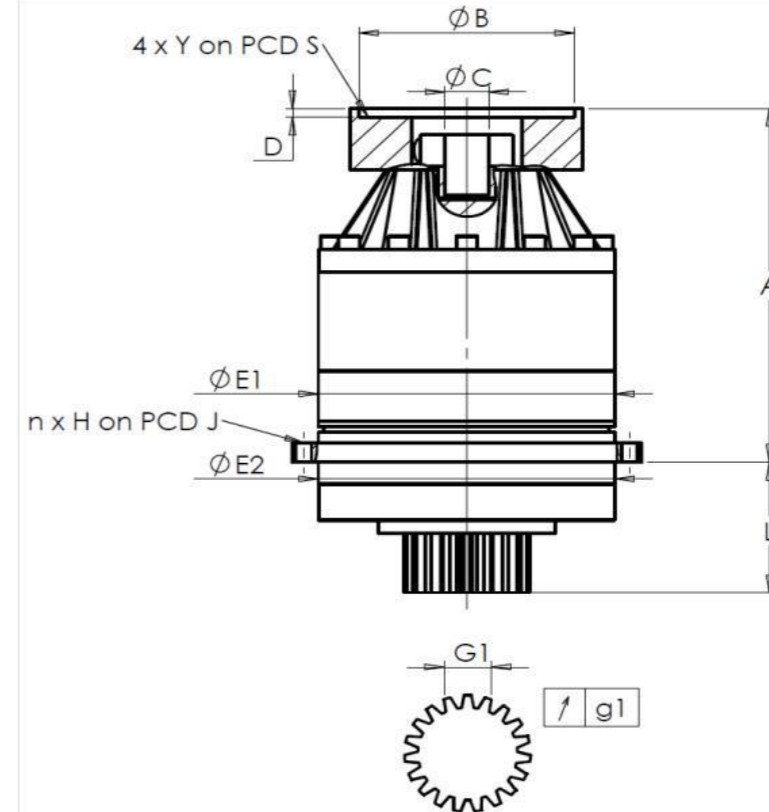

General tolerance: Js13 Cmm Automatic / manual coordinate-measuring machine µm Micrometer Cr Calliper rule Di Dial indicator Pg Plug gauge

For the installation, please refer to User Manual KRP (182/008)

SPECIFIC REMARKS:

HOUSING				OUTPUT PINION				MOTOR FLANGE			
requirement		measure		requirement		measure		requirement		measure	
		E5504				F827					
E1	255h7 ⁰ _{-0,052} µm	254,98	Span dimension over 3 teeth				Ø B	181 µm	181		
E2	255h7 ⁰ _{-0,052} µm	254,98	G1	39,25 ⁰ _{-0,03} Cmm	39,23	Ø C	38 ^{+0,05} _{+0,025} µm	38,035			
n x H on PCD J	16 Ø13,5 on PCD 280	Cr 16 Ø13,5 on PCD 280	g1	0,022 Di	0,02	Ø D	8 Cr	8,48			
A	328,5 µm	329,23	No-load input torque				Ø S1	215 Cr	215		
L	121 µm	121,3	Line 1		2,5 Nm	Ø Y1	M12 Pg	M12			

Noise level		
	Line	Stiffness
@1600 rpm input (dB(A)) 66,5		
Torsional stiffness (Nm/arcmin)	1	473,03
Radial stiffness (N/µm)	1	1172

Date: **01/12/2022**

Visa: **C DE MIRANDA**

Version: **A**

Product images are for illustrative purposes only.