

CUSTOMER: **IO GUOWEI** CUSTOMER ORDER REF: **RXCN2022042720_IO GUOWEI**
 DISTRIBUTOR: **REDEX SHANGHAI REPAIRING** REDEX ORDER REF: **216909**
 DESIGNATION: **KRP4+M.46.3.H.35/48** SERIAL NUMBER: **906860**
 CODE: **RX128414-13** MOTOR FLANGE CODE: **RX128583-01**

EXTERNAL DIMENSIONS & INTERFACES: SN: **906860**

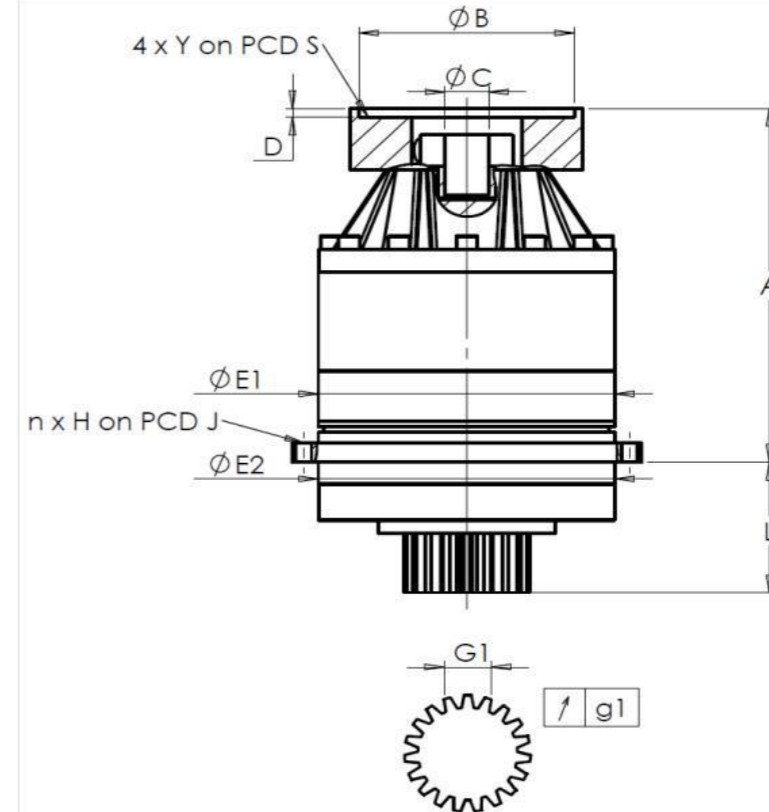

General tolerance: Js13 Cmm Automatic / manual coordinate-measuring machine µm Micrometer Cr Calliper rule Di Dial indicator Pg Plug gauge

For the installation, please refer to User Manual KRP (182/008)

SPECIFIC REMARKS:

HOUSING				OUTPUT PINION				MOTOR FLANGE			
requirement		measure		requirement		measure		requirement		measure	
		E6464				H723					
E1	285h7 ⁰ _{-0,052} µm	284,98	Span dimension over 3 teeth				Ø B	181 µm	181		
E2	285h7 ⁰ _{-0,052} µm	284,98	G1	46,9 ⁰ _{-0,03} Cmm	46,885	Ø C	38 ^{+0,05} _{+0,025} µm	38,025			
n x H on PCD J	16 Ø14 on PCD 310	16 Ø14 on PCD 310	g1	0,022	0,015	Ø D	8	8,52			
A	373,5 µm	374,22	No-load input torque				Ø S1	215	215		
L	141 µm	140,91	Line 1		0,8 Nm	Ø Y1	M12	M12			

Noise level		
	Line	Stiffness
@1300 rpm input (dB(A)) 65,0		
Torsional stiffness (Nm/arcmin)	1	574,81
Radial stiffness (N/µm)	1	1261

Date: **06/09/2022**

Visa: **C DE MIRANDA**

Version: **A**

Product images are for illustrative purposes only.